

## D7212 Control/Communicator Installation and Troubleshooting Quick Reference

### Introduction

This reference contains the very basic information a trained installer needs to install and troubleshoot a D7212 system. See the *D7212 Operation and Installation Manual* (74-06913-000) for a complete description of the D7212 and detailed installation instructions.



### Installing Optional Modules?

***Do not use the instructions packaged with the D128 Phone Line Switcher, D8125 POPEX Module, D8128A OctoPOPIT Module, D8129 OctoRelay Module, or D811 Arm Status Relay Module.***

The *D7212 Operation and Installation Manual* (74-06913-000) contains instructions for installing these modules.

<b>Basic Troubleshooting .....</b>	<b>2</b>
Command 5 7 Toggles Default Idle Text .....	2
Command 5 9 Shows Firmware Revision .....	2
Problems with Points .....	3
<b>System Wiring Diagram, Issue A .....</b>	<b>6</b>
<b>Troubleshooting Continued .....</b>	<b>8</b>
Problems with Points (Continued from page 5) .....	8
Problems with Command Centers .....	8
Problems Programming the Panel .....	9
Phone Line Trouble .....	10
Communications Failure .....	10
<b>Quick Reference Terminal Description .....</b>	<b>12</b>

# Basic Troubleshooting

## Command 5 7 Toggles Default Idle Text

Command 5 7 allows technicians who might not be familiar with the custom idle text to confirm whether an area is armed, ready to arm, or not ready to arm. The default idle text displays are:

**AREA # IS ON    AREA # IS OFF**

Follow the procedure below to toggle between custom and default idle text.

1. Ensure the command center is at idle text.
2. Press **COMMAND 5 7**.
3. The display will change to default idle text for 5 seconds and then revert to its original idle text.

## Command 5 9 Shows Firmware Revision

Command 5 9 displays the revision of firmware currently installed in the panel.

1. Ensure the command center is at idle text.
2. Press **COMMAND 5 9**.
3. The current revision of firmware displays (**7212 REV ## - ##**) for 5 seconds and returns to idle text.

## Problems with Points

Symptom	Diagnosis	Remedy
Point appears as missing at command centers and in reports to the receiver.	POPIT is not connected or incorrectly connected to the data expansion loop.	Disconnect the EOL resistor from the loop output of the POPIT. You should measure 8 to 13 VDC, constant.
	Sensor loop switch (1 to 8) is turned off on OctoPOPIT.	If the sensor loop switch on an OctoPOPIT is turned off for a programmed point, the point reports as missing.
	Switch 12 ON for more than one OctoPOPIT connected to ZONEX.  Switch 12 ON for OctoPOPIT connected to same ZONEX as a D8125.	Connect only one OctoPOPIT with switch 12 ON to ZONEX.  If ZONEX is connected to a D8125, turn switch 12 OFF for all OctoPOPITs connected to that terminal.
	POPIT is not programmed correctly.	Verify that the switches on the POPIT are set for the missing POPIT number. Switches set incorrectly can cause both missing and extra POPITs.
Points intermittently appear as missing. Points are erratic.	Problem with data expansion loop.	See <i>Problems with Data Expansion Loop</i> .
	Debounce Count parameter set at 1. If an off-board point is in transition between normal and faulted conditions as the panel scans it, it appears as missing.	Radionics recommends that the Debounce Count be left at the default of 2.  Decreasing the Debounce Count to 1 may cause points to appear as missing. Increasing the Debounce may cause missed alarms.

## Problems with Points (Continued)

Symptom	Diagnosis	Remedy
One or more points remain in trouble or alarm with all devices connected to the sensor loops normal.	The sensor loop is open, shorted, or grounded.  Opens, shorts, or grounds cause troubles or alarms depending on point programming.	Remove the sensor loop from the D7212 or POPIT and meter it for continuity. There should be no more than 100Ω resistance, plus the value of the end of line resistor on the wires. If you meter less resistance than the value of the end of line resistor, check the wiring for shorts.  With the wires for the loop removed, meter them for continuity to ground. A ground before the end of line resistor on an on-board point's sensor loop is interpreted as a short. A ground on a sensor loop for a POPIT point is interpreted as an open.
Faulted points do not generate alarms or troubles as programmed.	Command 47 pressed at the time the alarm or trouble was generated.	The D7212 ignores input from all points in the same area programmed for sensor reset during sensor reset (Command 47).
	Two points are programmed with the same address.	Points programmed with the same address do not function correctly. Check to be certain that you have not duplicated point addresses.
Panel transmits PT BUS TROUBLE reports. Erroneous alarm and/or trouble reports may follow PT BUS TROUBLE report. Erroneous alarm and/or trouble events for off-board points appear at command centers.	Short on D8125 POPEX module's Data Expansion Loop or short on D7212's ZONEX data terminals (27 & 28).	A short on the Data Expansion Loop or the ZONEX data terminals generates a PT BUS TROUBLE report.  While the short remains, the panel responds as though the sensor loop for each point connected to the POPEX module was shorted.  Check wiring for shorts.
	A POPIT has its switches set incorrectly and it's sensor loop is shorted.	Check to be certain all POPIT switches are set correctly.

# System Wiring Diagram, Issue A

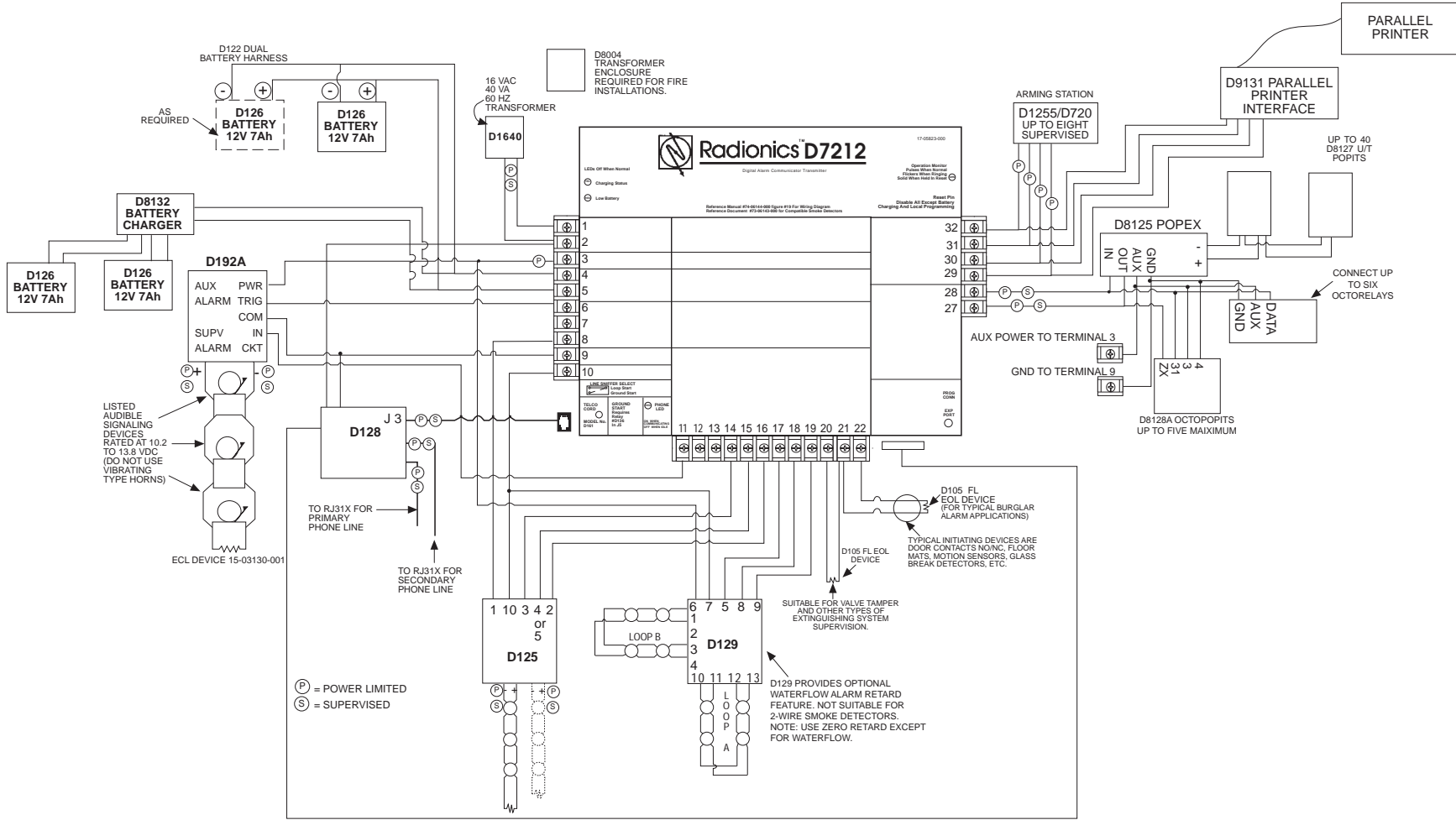

## Troubleshooting Continued

### Problems with Points (Continued from page 5)

Symptom	Diagnosis	Remedy
All off-board points are MISSING.	Short on Aux Power, terminal 3.	Terminal 3 shares a common circuit breaker. Check wiring and devices connected to this terminal for shorts or grounds.

### Problems with Command Centers

Symptom	Diagnosis	Remedy
Command centers show erratic behavior.  For example, the pip that confirms you pressed a key "echoes" or the back lighting flashes off and on.	A supervised address has been entered in more than one command center.	Entering a supervised address in more than one command center causes erratic behavior.  Use a supervised address in one command center only.
	One or more of the keys is stuck under the faceplate	Press each of the keys on the command center to be certain none of them is stuck.
	Data connections (yellow and green wires) on one or more command centers are reversed, or only one wire is connected.	Check to be sure that the yellow and green data wires are correctly connected at all command centers.
NO AUTHORITY displays at command center when you enter your passcode to perform a function.	<p>Check the <i>User Interface</i> section of the program to be sure the function is enabled for Authority Level assigned to the passcode in the <i>Passcode Work sheet</i> section of the program.</p> <p>Check the <i>Passcode Worksheet</i> section of the program to be certain the passcode is assigned to the area where you are attempting to perform the function.</p> <p>Check the <i>Passcode Worksheet</i> section of the program to see if the passcode is restricted by a user window.</p> <p>Check the <i>Area Parameters</i> section of the program to be certain the area you are attempting to perform the function in is turned on.</p>	

## Problems Programming the Panel

Before attempting to program the D7212, you should be familiar with the basic operation of the D5200 programmer. See the *D5200 Operation Manual* (74-06176-000). If you still experience problems, check for the symptoms below.

Symptom	Diagnosis	Remedy
The programmer displays PLUG IN 7212 when you press SEND or RECV.	The programmer is not correctly connected to the D7212.	<ol style="list-style-type: none"> <li>1. Verify that the data/power cord is plugged into the COMMUNICATOR port on the D5200.</li> <li>2. Verify that the data/power cord is plugged securely into the D5200 programmer.</li> <li>3. Check each conductor in the data/power cord for continuity.</li> </ol>
	AC induction through the on-board point sensor loops, the DATA BUS, or the ZONEX BUS.	<ol style="list-style-type: none"> <li>1. Verify a proper earth ground at terminal 10.</li> <li>2. Disconnect on-board point sensor loops, the DATA BUS (terminals 30, 31), and the ZONEX BUS (terminals 27,28).</li> </ol>
After plugging in the programmer, the panel transmits SDI trouble reports for supervised SDI devices (command centers, printer interface modules, etc.). All SDI devices stop operating.	You haven't entered the D7212 handler within 30 seconds of plugging in the programmer.	<p>Enter the D7212 handler within 30 seconds of plugging in the programmer.</p> <p>Once the SDI reports are generated, entering the handler or disconnecting the programmer returns the SDI devices to normal operation.</p>



## Phone Line Trouble

Phone line problems can result in the D7212 going into Communications Failure.

Symptom	Diagnosis	Remedy
SERV PH LINE #1 (or 2 if two lines are used) appears in command center display.	D7212's phone line monitor detects a phone line as faulted.	<ol style="list-style-type: none"> <li>1. Verify that the telephone cord is correctly connected to the RJ31X and the D7212.</li> <li>2. Verify the Ground Start Jumper is in the correct position.</li> <li>3. If using a ground start phone line, verify D136 relay is in socket K6/J5.</li> <li>4. Verify that the RJ31X jack is wired correctly. The incoming phone line must be wired to terminals 4 and 5. The in house phone system must be wired to terminals 1 and 8.</li> <li>5. Verify that all telephones are on-hook. Leaving a telephone on hold after the other party hangs up creates an off-hook condition. Verify that no phones are on hold.</li> </ol> <p>If completing the steps above does not restore the phone line, meter the phone lines. You should meter at least 7.5 VDC when the line is idle (on-hook). You should meter at least 13 mA of current when the line is active (off-hook). If your readings are below the minimum values, contact your telephone company repair service.</p>

## Communications Failure

Follow the *Phone Line Trouble* procedure to verify that there is no problem with the phone lines at the D7212 installation. If the phone lines are good, monitor the lines (preferably at the receiver) for the symptoms listed below.

Symptom	Diagnosis	Remedy
The receiver answers the call and provides an initial "handshake" acknowledgment, but does not acknowledge the D7212's report transmission with a "kiss-off" acknowledgment .	The receiver is not compatible with the D7212's transmission format.	<p>Verify that the receiver is compatible with the format the D7212 is using (either BFSK or Modem II). See <i>Phone</i> in the <i>D7212 Program Entry Guide</i> (74-06915-000).</p> <p>Modem II requires D6500 MPU and Line Card EPROM revision 6.00 or higher.</p>
	Noisy phone lines are interfering with report transmission.	Try making a voice call to the receiver on the line to verify the noisy condition. It may be necessary to have the phone company check the lines.



## Communications Failure (Continued)

Symptom	Diagnosis	Remedy
<p>The line rings but the D6500 receiver does not pick up.</p> <p>RING indicator on line card does not light. Can not hear ring with headset at receiver location.</p>	Line is not ringing at the receiver.	<ol style="list-style-type: none"> <li>1. Verify that the lines are correctly connected to the receiver.</li> <li>2. Verify that correct prefixes and phone numbers for the receiver have been programmed into the D7212.</li> </ol> <p>If completing the steps above does not correct the problem, contact your telephone company repair service.</p>
<p>The line rings but the receiver does not pick up.</p> <p>RING indicator on line card lights. Can hear ring with test set at receiver location.</p>	Line card in receiver may be faulty.	Review receiver manuals for trouble shooting procedures.
<p>The D7212 reaches a busy signal for all ten attempts to reach the receiver.</p>	Calls are not reaching the receiver.	<ol style="list-style-type: none"> <li>1. Verify that correct prefixes and phone numbers for the receiver have been programmed into the D7212.</li> <li>2. Verify that the phone lines are not shorted between the phone company's equipment and the receiver by placing a call to the number for the receiver. If you hear the line ring, but the ring detector doesn't light, or if you hear a busy signal and the green on line (OL) indicator is not lit, call the phone company for service.</li> </ol>
	The receiver's call load is too great.	Additional line cards and phone lines may be needed for the receiver.
<p>The receiver answers the call and provides an acknowledgment tone, but the communicator does not transmit reports.</p>	The receiver is not producing the correct acknowledgement tone.	Verify that the receiver is producing a 1400 Hz, 2300 Hz, or Modem II acknowledgment tone.
	The D136 relay in J10 for ground start phone systems is inserted incorrectly.	Insert the D136 relay in socket J10 correctly. See the <i>Relays</i> section of this manual for instructions.

# Quick Reference Terminal Description

Terminal	Name	Description
1, 2	CLASS 2 TRANSFORMER	Connect 16.5 VAC, 40 VA transformer for primary power supply.
3	+ AUX POWER	Supplies up to 1.4A at 10.0 VDC to 13.9 VDC to powered devices. Use terminal 9 for common.
4	BATTERY NEGATIVE ONLY	Connect 12V, 7Ah rechargeable lead acid type battery's negative terminal (-) to terminal 4.
5 (+)	BATTERY POSITIVE ONLY	Connect 12V, 7Ah rechargeable lead acid type battery's positive terminal (+).
6 (+)	+ STEADY OR PULSED	Supplies up to 2 A at 10.0 VDC to 13.9 VDC for steady or pulsed alarm output. Use terminal 9 for common. Programmed as Relay A. Shares circuit breaker with terminals 7 and 8.
7 (+)	+ ALTERNATE	Supplies up to 2 A at 10.0 VDC to 13.9 VDC for steady or pulsed alarm output. Use terminal 9 for common. Programmed as Relay B. Shares circuit breaker with terminals 6 and 8. <b>D136 Plug-in Relay required:</b> Install a D136 in socket K3 for output at terminal 7.
8 (+)	+ SWITCHED AUX POWER	Supplies up to 1.4 Amps at 10.0 VDC to 13.9 VDC. Use terminal 9 for common. Programmed as Relay C. Continuous output interrupted by CMD 47 or alarm verification. Shares circuit breaker with terminals 6 and 7. <b>D136 Plug-in Relay required:</b> Install a D136 in socket K1 for output at terminal 8.
9	COMMON	Terminal 9 is common for Auxiliary Power, Alarm Power, Alternate Alarm Power, and Switched Aux Power (terminals 3, 6, 7, and 8).
10	EARTH GROUND	Connect to earth ground. A cold water pipe or grounding rod is preferred. Do not connect to telephone or electrical ground.
11, 13, 14, 16, 17, 19, 20, 22	ON-BOARD POINTS (Inputs)	Connect normally open and/or normally closed detection devices to loop wiring. 1 kΩ resistor required at end of loop.
12, 15, 18, 21	ON-BOARD POINTS (Common)	Loop returns for on-board points.
27 28	ZONEX IN 1 ZONEX OUT 1	Connect ZONEX module for points 9 to 48 and Octorelay modules for relays 1 to 48 to these terminals.
29 (-)	COMMON	Common terminal for SDI devices
30 31	DATA BUS B DATA BUS A	Terminals 30 and 31 are a two wire bus that drives the command centers, printer interface, and other SDI devices.
32 (+)	POWER +	Power for command centers, printer interface and other SDI devices. This separate protected power output for SDI devices is not affected by shorts on any other terminal.

© 1992 Radionics, Inc., Salinas, CA, U.S.A. All rights reserved.

™ The Radionics logo is a registered trademark of Radionics, Inc., Salinas, CA.

Radionics, Inc., 1800 Abbott Street  
Salinas, CA, 93901, U.S.A.